

FEM SUB 13 -28KG

Competidores

Competidores: 2

Nº	Nombre	Kyu	Club	1	2	1	2	1	2	Victs.	Pts.	Pos.
1	VERA DANA	?	NTE		10		10			2	20	1
2	DIAZ ANGIE	?	SAN							0	0	2

Combates

Comb.	Blanco	Azul	Resultado	Tiempo
1	VERA DANA	1 2 DIAZ ANGIE	10-00	0:00
2	VERA DANA	1 2 DIAZ ANGIE	10-00	0:00
3	VERA DANA	1 2 DIAZ ANGIE		

Clasificación

Pos.	Nombre
1	VERA DANA, NTE
2	DIAZ ANGIE, SAN

FEM SUB 13 -34KG

Competidores

Competidores: 2

Nº	Nombre	Kyu	Club	1	2	1	2	1	2	Victs.	Pts.	Pos.
1	BERMUDEZ MARIA	?	VAL		10				10	2	20	1
2	RINCON MAILYNG	?	CAS			10				1	10	2

Combates

Comb.	Blanco	Azul	Resultado	Tiempo
1	BERMUDEZ MARIA	1 2 RINCON MAILYNG	10-00	0:00
2	BERMUDEZ MARIA	1 2 RINCON MAILYNG	00-10	0:00
3	BERMUDEZ MARIA	1 2 RINCON MAILYNG	10-00	0:47

Clasificación

Pos.	Nombre
1	BERMUDEZ MARIA, VAL
2	RINCON MAILYNG, CAS

FEM SUB 13 -38KG

Competidores

Competidores: 5

Nº	Nombre	Kyu	Club	1	2	3	4	5	Victs.	Pts.	Pos.
1	MELDIVELSO DAIRY	?	CAS				10		1	10	4
2	PALECHOR ALLISON	?	VAL	10		10	10	10	4	40	1
3	MARTINEZ DANNA	?	CES	10			10		2	20	3
4	CORRALES DULCE	?	CUN						0	0	5
5	VARGAS CATALINA	?	BOG	10		10	10		3	30	2

Combates

Comb.	Blanco	Azul	Resultado	Tiempo
1	CORRALES DULCE 4	VARGAS CATALINA 5	00-10	0:00
2	MELDIVELSO DAIRY 1	PALECHOR ALLISON 2	00s2-10	2:00
3	MARTINEZ DANNA 3	CORRALES DULCE 4	10-00	0:18
4	MELDIVELSO DAIRY 1	VARGAS CATALINA 5	00-10s1	1:24
5	PALECHOR ALLISON 2	MARTINEZ DANNA 3	10-00s3	1:38
6	MELDIVELSO DAIRY 1	CORRALES DULCE 4	10-00	0:49
7	MARTINEZ DANNA 3	VARGAS CATALINA 5	00-10	0:56
8	PALECHOR ALLISON 2	CORRALES DULCE 4	10-00	0:22
9	MELDIVELSO DAIRY 1	MARTINEZ DANNA 3	00-10	0:43
10	PALECHOR ALLISON 2	VARGAS CATALINA 5	10s1-00	1:47

Clasificación

Pos.	Nombre
1	PALECHOR ALLISON, VAL
2	VARGAS CATALINA, BOG
3	MARTINEZ DANNA, CES
4	MELDIVELSO DAIRY, CAS
5	CORRALES DULCE, CUN

FEM SUB 13 -42KG

Competidores

Competidores: 3

Nº	Nombre	Kyu	Club	1	2	3	Victs.	Pts.	Pos.
1	PAEZ TANIA	?	BOG				0	0	3
2	ABRIL DAMARYS	?	CAS	10			1	10	2
3	RESTREPO MARIA	?	RIS	10	1		2	11	1

Combates

Comb.	Blanco		Azul		Resultado	Tiempo
1	PAEZ TANIA	1	2	ABRIL DAMARYS	00-10	0:12
2	PAEZ TANIA	1	3	RESTREPO MARIA	00s1-10	1:20
3	ABRIL DAMARYS	2	3	RESTREPO MARIA	00-01	2:00

Clasificación

Pos.	Nombre
1	RESTREPO MARIA, RIS
2	ABRIL DAMARYS, CAS
3	PAEZ TANIA, BOG

FEM SUB 13 -47KG

Competidores

Competidores: 3

Nº	Nombre	Kyu	Club	1	2	3	Victs.	Pts.	Pos.
1	VEGA LIZ	?	CES		10	10	2	20	1
2	TORRES ANGELICA	?	CUN			10	1	10	2
3	GONZALES NICOLL	?	VAL				0	0	3

Combates

Comb.	Blanco		Azul	Resultado	Tiempo
1	VEGA LIZ	1 2	TORRES ANGELICA	10-00s1	1:19
2	VEGA LIZ	1 3	GONZALES NICOLL	10-00	1:22
3	TORRES ANGELICA	2 3	GONZALES NICOLL	10-00	2:00

Clasificación

Pos.	Nombre
1	VEGA LIZ, CES
2	TORRES ANGELICA, CUN
3	GONZALES NICOLL, VAL

FEM SUB 13 -52KG

Competidores

Competidores: 2

Nº	Nombre	Kyu	Club	1	2	1	2	1	2	Victs.	Pts.	Pos.
1	RAHAMUT RUXANDRA	?	ANT							0	0	2
2	UMAÑA GABRIELA	?	VAL	10		10				2	20	1

Combates

Comb.	Blanco		Azul	Resultado	Tiempo
1	RAHAMUT RUXANDRA	1	2	UMAÑA GABRIELA	00-10 1:11
2	RAHAMUT RUXANDRA	1	2	UMAÑA GABRIELA	00-10 0:16
3	RAHAMUT RUXANDRA	1	2	UMAÑA GABRIELA	

Clasificación

Pos.	Nombre
1	UMAÑA GABRIELA, VAL
2	RAHAMUT RUXANDRA, ANT

FEM SUB 13 +52KG

Competidores

Competidores: 1

Nº	Nombre	Kyu	Club	1	Victs.	Pts.	Pos.
1	SALAZAR ISABELLA	?	ANT		0	0	1

Combates

Comb.	Blanco	Azul	Resultado	Tiempo

Clasificación

Pos.	Nombre
1	SALAZAR ISABELLA, ANT

MAS SUB 13 -28KG

Competidores

Competidores: 1

Nº	Nombre	Kyu	Club	1	Victs.	Pts.	Pos.
1	MARROQUIN JUAN	?	NTE		0	0	1

Combates

Comb.	Blanco	Azul	Resultado	Tiempo

Clasificación

Pos.	Nombre
1	MARROQUIN JUAN, NTE

MAS SUB 13 -31KG

Competidores

Competidores: 4

Nº	Nombre	Kyu	Club	1	2	3	4	Victs.	Pts.	Pos.
1	CASTILLO FELIPE	?	CUN					0	0	4
2	PINTO JHOAN	?	CES	10		10	10	3	30	1
3	SANDOVAL JUAN	?	RIS	10				1	10	3
4	SIERRA DAVID	?	CAS	10		10		2	20	2

Combates

Comb.	Blanco		Azul	Resultado	Tiempo
1	CASTILLO FELIPE	1	2 PINTO JHOAN	00-10	0:00
2	SANDOVAL JUAN	3	4 SIERRA DAVID	00-10	0:00
3	CASTILLO FELIPE	1	3 SANDOVAL JUAN	00-10	0:00
4	PINTO JHOAN	2	4 SIERRA DAVID	10-00	0:00
5	CASTILLO FELIPE	1	4 SIERRA DAVID	00-10	0:00
6	PINTO JHOAN	2	3 SANDOVAL JUAN	10-00	0:00

Clasificación

Pos.	Nombre
1	PINTO JHOAN, CES
2	SIERRA DAVID, CAS
3	SANDOVAL JUAN, RIS
4	CASTILLO FELIPE, CUN

MAS SUB 13 -34KG

Competidores: 7

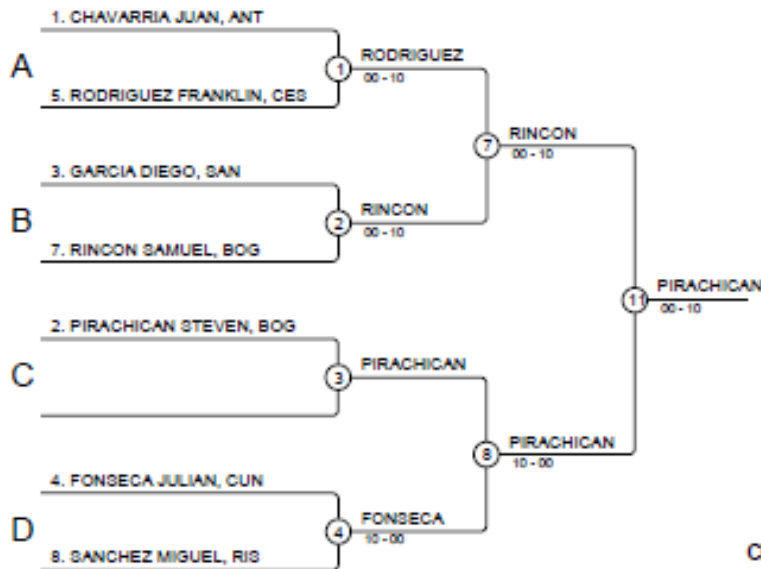

Clasificación

Pos.	Nombre
1	PIRACHICAN STEVEN, BOG
2	RINCON SAMUEL, BOG
3	GARCIA DIEGO, SAN
3	RODRIGUEZ FRANKLIN, CES
5	FONSECA JULIAN, CUN
5	SANCHEZ MIGUEL, RIS
7	CHAVARRIA JUAN, ANT
7	

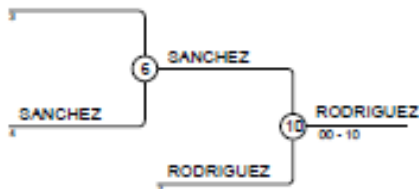
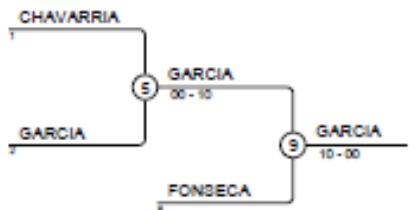

MAS SUB 13 -38KG

Competidores: 5

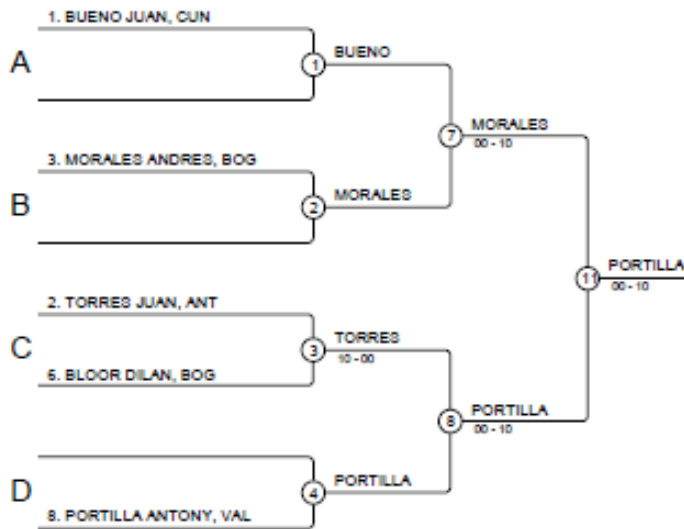

Clasificación

Poc.	Nombre
1	PORTILLA ANTONY, VAL
2	MORALES ANDRES, BOG
3	TORRES JUAN, ANT
3	BLOOR DILAN, BOG
5	
5	BUENO JUAN, CUN
7	
7	

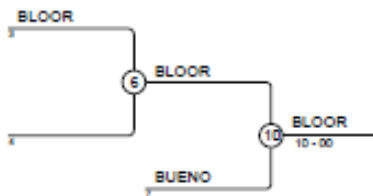

MAS SUB 13 -42KG

Competidores

Competidores: 1

Nº	Nombre	Kyu	Club	1	Victs.	Pts.	Pos.
1	SALCEDO LEONARDO	?	BOG		0	0	1

Combates

Comb.	Blanco	Azul	Resultado	Tiempo

Clasificación

Pos.	Nombre
1	SALCEDO LEONARDO, BOG

MAS SUB 13 -47KG

Competidores

Competidores: 4

Nº	Nombre	Kyu	Club	1	2	3	4	Victs.	Pts.	Pos.
1	RODRIGUEZ EMANUEL	?	BOG		10	10	10	3	30	1
2	PINEDA ELIAS	?	BOG				10	1	10	3
3	CORREA LUIS	?	VAL		10		10	2	20	2
4	CHANAGA EDWARD	?	SANT					0	0	4

Combates

Comb.	Blanco	Azul	Resultado	Tiempo
1	RODRIGUEZ EMANUEL 1	2 PINEDA ELIAS	10-00	0:00
2	CORREA LUIS 3	4 CHANAGA EDWARD	10-00	0:00
3	RODRIGUEZ EMANUEL 1	3 CORREA LUIS	10-00	0:00
4	PINEDA ELIAS 2	4 CHANAGA EDWARD	10-00	0:00
5	RODRIGUEZ EMANUEL 1	4 CHANAGA EDWARD	10-00	0:00
6	PINEDA ELIAS 2	3 CORREA LUIS	00-10	0:00

Clasificación

Pos.	Nombre
1	RODRIGUEZ EMANUEL, BOG
2	CORREA LUIS, VAL
3	PINEDA ELIAS, BOG
4	CHANAGA EDWARD, SANT

MAS SUB 13 -52KG

Competidores

Competidores: 2

Nº	Nombre	Kyu	Club	1	2	1	2	1	2	Victs.	Pts.	Pos.
1	VERA WILSON	?	BOG		10				10	2	20	1
2	ORDOÑEZ JUAN	?	CES			10				1	10	2

Combates

Comb.	Blanco	Azul	Resultado	Tiempo
1	VERA WILSON	1 2 ORDOÑEZ JUAN	10-00	0:00
2	VERA WILSON	1 2 ORDOÑEZ JUAN	00-10	0:00
3	VERA WILSON	1 2 ORDOÑEZ JUAN	10-00	0:00

Clasificación

Pos.	Nombre
1	VERA WILSON, BOG
2	ORDOÑEZ JUAN, CES

MAS SUB 13 +52KG

Competidores

Competidores: 3

Nº	Nombre	Kyu	Club	1	2	3	Victs.	Pts.	Pos.
1	SANABRIA PABLO	?	NTE		10	10	2	20	1
2	PEÑA CARLOS	?	CUN				0	0	3
3	MORA JAIDER	?	MET		10		1	10	2

Combates

Comb.	Blanco	Azul	Resultado	Tiempo
1	SANABRIA PABLO	1 2 PEÑA CARLOS	10-00	0:00
2	SANABRIA PABLO	1 3 MORA JAIDER	10-00	0:00
3	PEÑA CARLOS	2 3 MORA JAIDER	00-10	0:00

Clasificación

Pos.	Nombre
1	SANABRIA PABLO, NTE
2	MORA JAIDER, MET
3	PEÑA CARLOS, CUN

MAS SUB 15 -36KG

Competidores

Competidores: 4

Nº	Nombre	Kyu	Club	1	2	3	4	Victs.	Pts.	Pos.
1	AVELLA MELKIS	?	CUN					0	0	4
2	ANAYA MANUEL	?	CUN	10				1	10	3
3	VALENCIA YEISON	?	RIS	10	10			2	20	2
4	ALVARES JUAN	?	CUN	10	10	10		3	30	1

Combates

Comb.	Blanco		Azul	Resultado	Tiempo
1	AVELLA MELKIS	1 2	ANAYA MANUEL	00-10	0:00
2	VALENCIA YEISON	3 4	ALVARES JUAN	00-10	0:00
3	AVELLA MELKIS	1 3	VALENCIA YEISON	00-10	2:10
4	ANAYA MANUEL	2 4	ALVARES JUAN	00-10	0:20
5	AVELLA MELKIS	1 4	ALVARES JUAN	00-10	0:21
6	ANAYA MANUEL	2 3	VALENCIA YEISON	00-10	0:17

Clasificación

Pos.	Nombre
1	ALVARES JUAN, CUN
2	VALENCIA YEISON, RIS
3	ANAYA MANUEL, CUN
4	AVELLA MELKIS, CUN

FEM SUB 15 -40KG

Competidores: 9

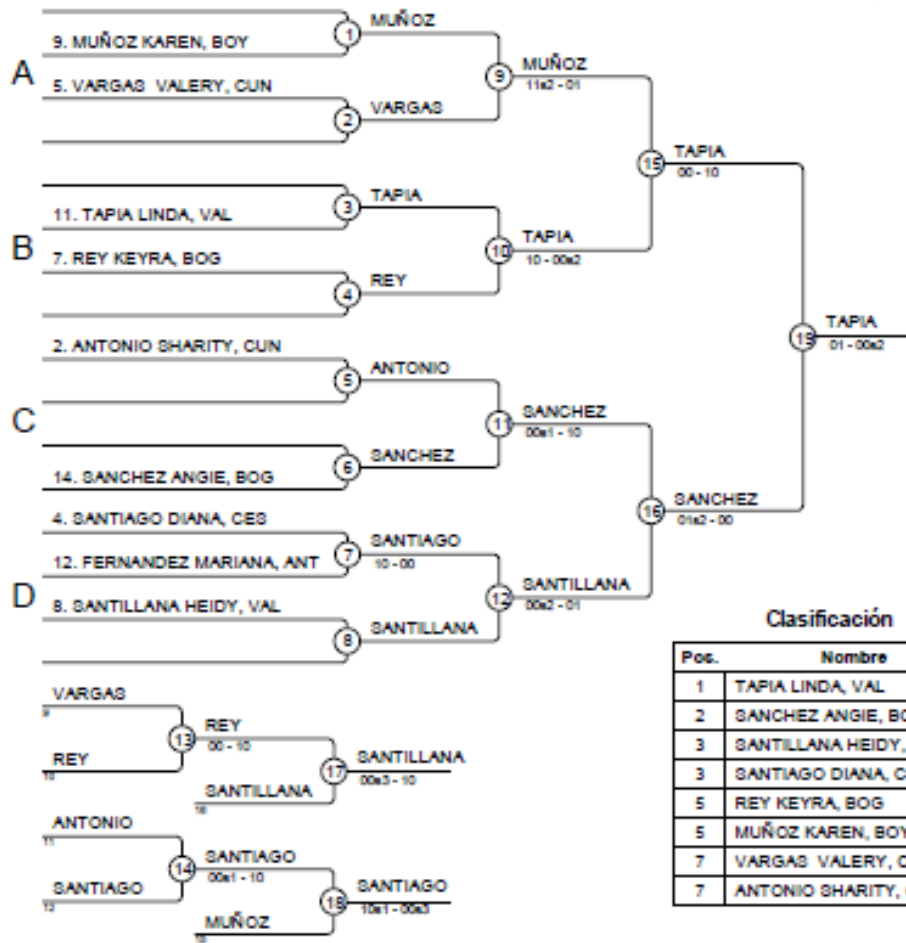

FEM SUB 15 -44KG

Competidores: 7

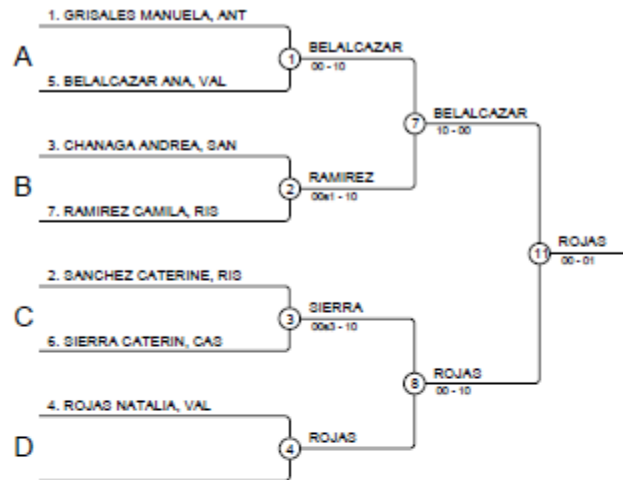

Clasificación

Pos.	Nombre
1	ROJAS NATALIA, VAL
2	BELALCAZAR ANA, VAL
3	SIERRA CATERIN, CAS
3	RAMIREZ CAMILA, RIS
5	CHANAGA ANDREA, SAN
5	SANCHEZ CATERINE, RIS
7	GRISALES MANUELA, ANT
7	

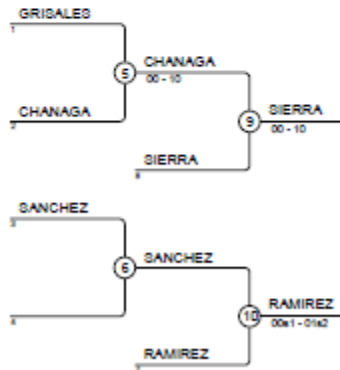

FEM SUB 15 -48KG

Competidores: 12

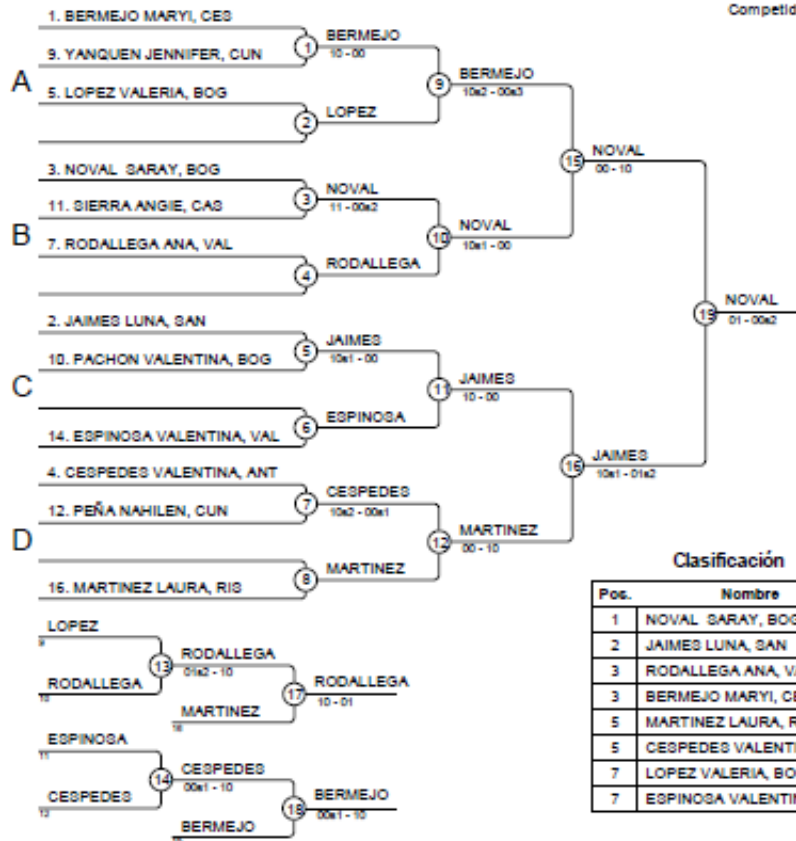

FEM SUB 15 -53KG

Competidores: 7

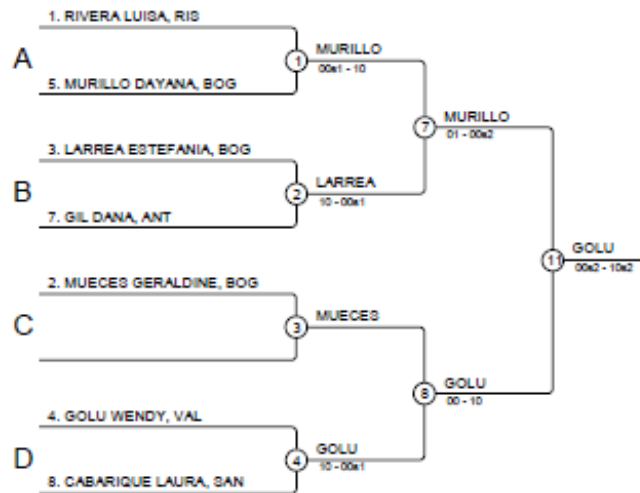

Clasificación

Pos.	Nombre
1	GOLU WENDY, VAL
2	MURILLO DAYANA, BOG
3	RIVERA LUISA, RIS
3	LARREA ESTEFANIA, BOG
5	MUECES GERALDINE, BOG
5	CABARIQUE LAURA, SAN
7	GIL DANA, ANT
7	

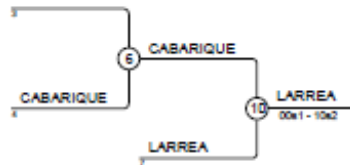
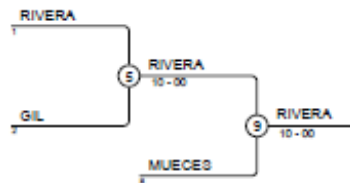

FEM SUB 15 -58KG

Competidores

Competidores: 4

Nº	Nombre	Kyu	Club	1	2	3	4	Victs.	Pts.	Pos.
1	AGUDELO KAREN	?	VAL		10	10	10	3	30	1
2	TRIANA RUTH	?	CAS					0	0	4
3	PRADO ERIKA	?	BOY		1			1	1	3
4	RINCON YARID	?	SAN		1	10		2	11	2

Combates

Comb.	Blanco		Azul	Resultado	Tiempo
1	AGUDELO KAREN	1 2	TRIANA RUTH	10-00	0:00
2	PRADO ERIKA	3 4	RINCON YARID	00-10	0:00
3	AGUDELO KAREN	1 3	PRADO ERIKA	10-00	1:28
4	TRIANA RUTH	2 4	RINCON YARID	00s1-01s2	3:00
5	AGUDELO KAREN	1 4	RINCON YARID	10-01	1:38
6	TRIANA RUTH	2 3	PRADO ERIKA	00s1-01s1	3:00

Clasificación

Pos.	Nombre
1	AGUDELO KAREN, VAL
2	RINCON YARID, SAN
3	PRADO ERIKA, BOY
4	TRIANA RUTH, CAS

FEM SUB 15 -64KG

Competidores

Competidores: 5

Nº	Nombre	Kyu	Club	1	2	3	4	5	Victs.	Pts.	Pos.
1	REALPE DANNA	?	VAL				10		1	10	4
2	HERNANDEZ DANIELA	?	BOG	10			10	10	3	30	2
3	CHOCO INGRID	?	VAL	10	10		10	10	4	40	1
4	CRUZ JARITH	?	BOG						0	0	5
5	PINILLA SHARA	?	BOG	10			10		2	20	3

Combates

Comb.	Blanco	Azul	Resultado	Tiempo
1	CRUZ JARITH	4 5 PINILLA SHARA	00-10	0:00
2	REALPE DANNA	1 2 HERNANDEZ DANIELA	00-10	0:00
3	CHOCO INGRID	3 4 CRUZ JARITH	10-00	0:00
4	REALPE DANNA	1 5 PINILLA SHARA	00-10	0:00
5	HERNANDEZ DANIELA	2 3 CHOCO INGRID	00-10	0:00
6	REALPE DANNA	1 4 CRUZ JARITH	10-00	0:00
7	CHOCO INGRID	3 5 PINILLA SHARA	10-00	0:00
8	HERNANDEZ DANIELA	2 4 CRUZ JARITH	10-00	0:00
9	REALPE DANNA	1 3 CHOCO INGRID	00-10	0:00
10	HERNANDEZ DANIELA	2 5 PINILLA SHARA	10-00	0:00

Clasificación

Pos.	Nombre
1	CHOCO INGRID, VAL
2	HERNANDEZ DANIELA, BOG
3	PINILLA SHARA, BOG
4	REALPE DANNA, VAL
5	CRUZ JARITH, BOG

FEM SUB 15 +64KG

Competidores

Competidores: 4

Nº	Nombre	Kyu	Club	1	2	3	4	Victs.	Pts.	Pos.
1	POLANCO LUZ	?	VAL			10		1	10	3
2	LLANTEN NINI	?	VAL	10		10		2	20	2
3	GRANADA JULIANA	?	ANT					0	0	4
4	PALACIOS ANGELINA	?	SAN	10	10	10		3	30	1

Combates

Comb.	Blanco	Azul	Resultado	Tiempo
1	POLANCO LUZ	1 2 LLANTEN NINI	00-10	0:00
2	GRANADA JULIANA	3 4 PALACIOS ANGELINA	00-10	0:00
3	POLANCO LUZ	1 3 GRANADA JULIANA	10-00	0:00
4	LLANTEN NINI	2 4 PALACIOS ANGELINA	00-10	0:00
5	POLANCO LUZ	1 4 PALACIOS ANGELINA	00-10	0:00
6	LLANTEN NINI	2 3 GRANADA JULIANA	10-00	0:00

Clasificación

Pos.	Nombre
1	PALACIOS ANGELINA, SAN
2	LLANTEN NINI, VAL
3	POLANCO LUZ, VAL
4	GRANADA JULIANA, ANT

MAS SUB 15 -36KG

Competidores

Competidores: 4

Nº	Nombre	Kyu	Club	1	2	3	4	Victs.	Pts.	Pos.
1	AVELLA MELKIS	?	CUN		10			1	10	3
2	ANAYA MANUEL	?	CUN					0	0	4
3	VALENCIA YEISON	?	RIS	10	10			2	20	2
4	ALVARES JUAN	?	CUN	10	10	10		3	30	1

Combates

Comb.	Blanco		Azul		Resultado	Tiempo
1	AVELLA MELKIS	1	2	ANAYA MANUEL	10-00	0:00
2	VALENCIA YEISON	3	4	ALVARES JUAN	00-10	0:00
3	AVELLA MELKIS	1	3	VALENCIA YEISON	00-10	2:10
4	ANAYA MANUEL	2	4	ALVARES JUAN	00-10	0:20
5	AVELLA MELKIS	1	4	ALVARES JUAN	00-10	0:21
6	ANAYA MANUEL	2	3	VALENCIA YEISON	00-10	0:17

Clasificación

Pos.	Nombre
1	ALVARES JUAN, CUN
2	VALENCIA YEISON, RIS
3	AVELLA MELKIS, CUN
4	ANAYA MANUEL, CUN

MAS SUB 15 -40KG

Competidores: 6

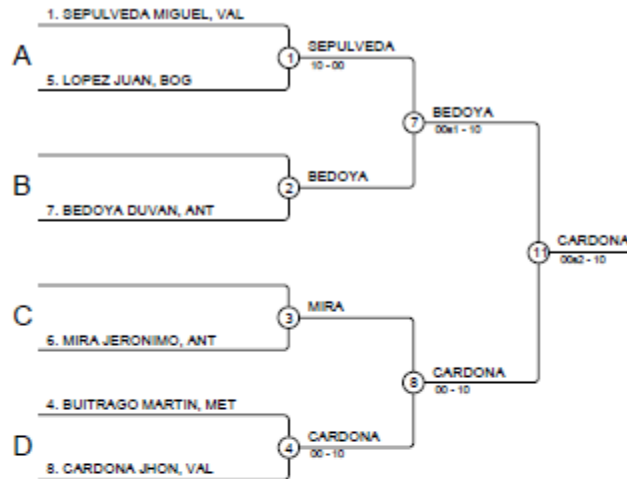

Clasificación

Pos.	Nombre
1	CARDONA JHON, VAL
2	BEDOYA DUVAN, ANT
3	MIRA JERONIMO, ANT
3	SEPULVEDA MIGUEL, VAL
5	LOPEZ JUAN, BOG
5	BUITRAGO MARTIN, MET
7	
7	

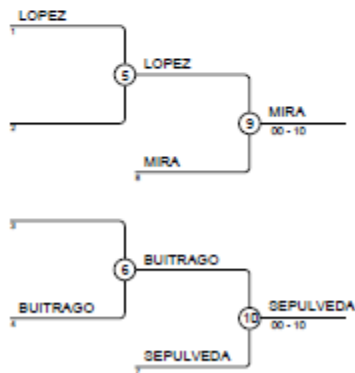

MAS SUB 15 -44KG

Competidores: 7

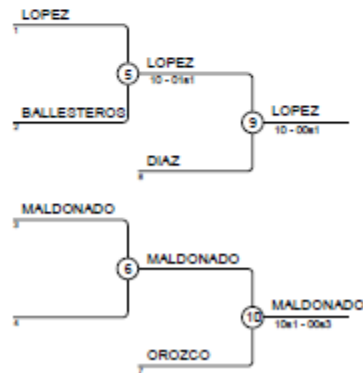
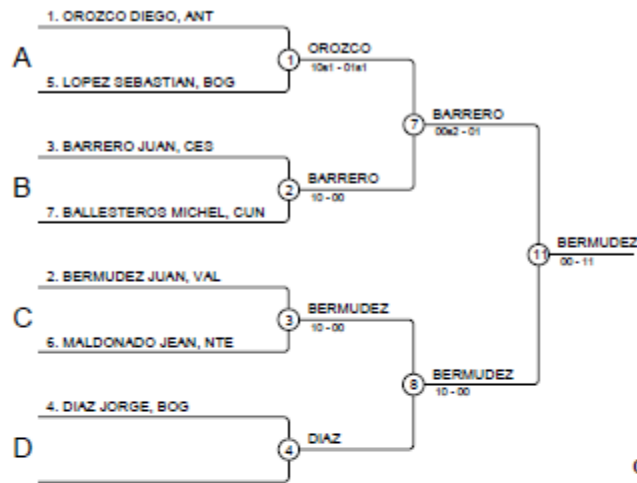

Clasificación

Pos.	Nombre
1	BERMUDEZ JUAN, VAL
2	BARRERO JUAN, CES
3	LOPEZ SEBASTIAN, BOG
3	MALDONADO JEAN, NTE
5	DIAZ JORGE, BOG
5	OROZCO DIEGO, ANT
7	BALLESTEROS MICHEL, CUN
7	

MAS SUB 15 -48KG

Competidores: 10

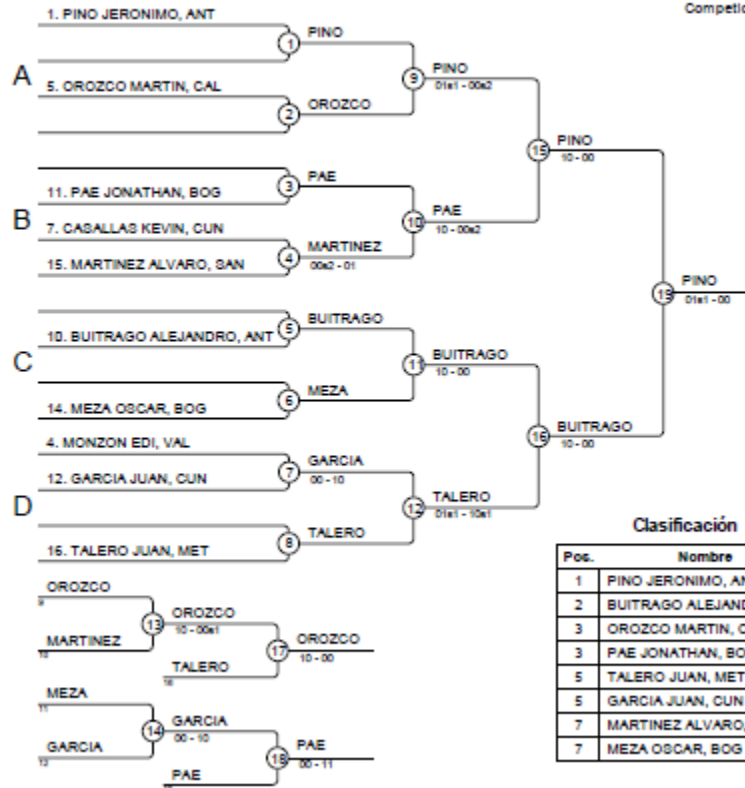

MAS SUB 15 -53KG

Competidores: 11

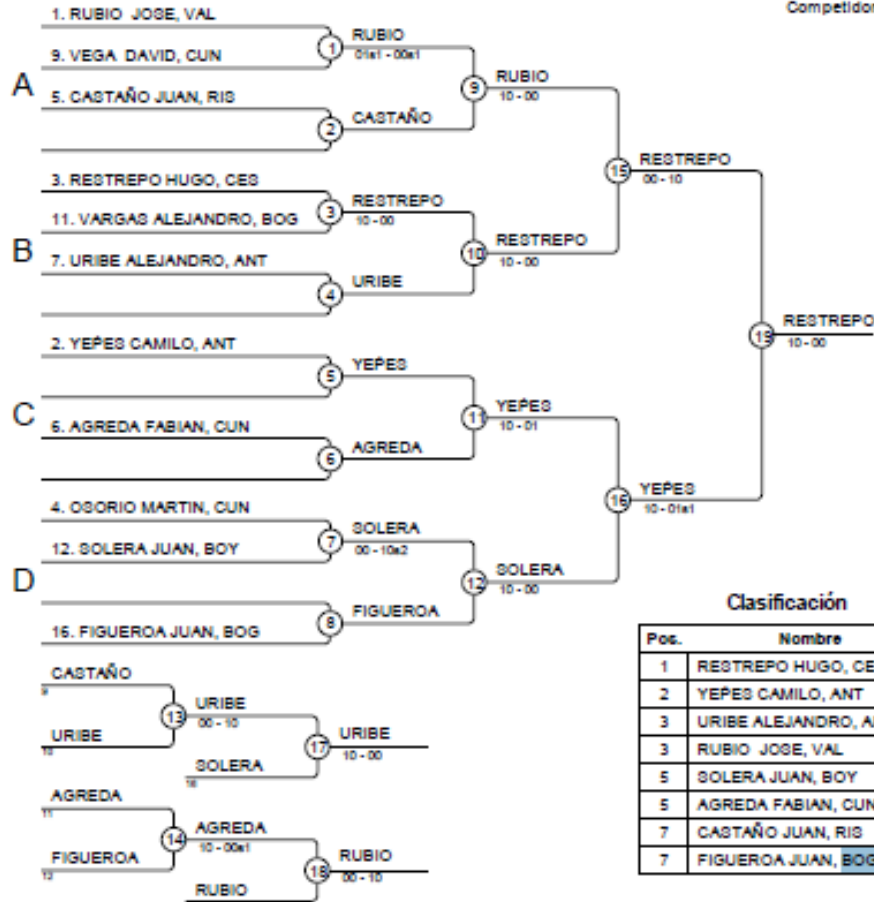

MAS SUB 15 -58KG

Competidores: 6

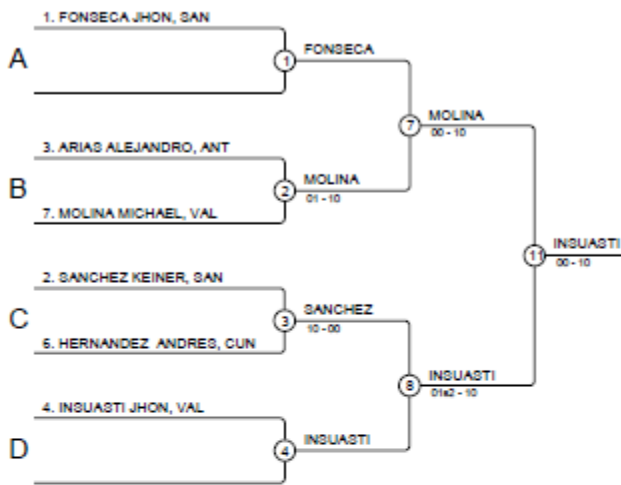

Clasificación

Poc.	Nombre
1	INSUASTI JHON, VAL
2	MOLINA MICHAEL, VAL
3	SANCHEZ KEINER, SAN
3	FONSECA JHON, SAN
5	ARIAS ALEJANDRO, ANT
5	HERNANDEZ ANDRES, CUN
7	
7	

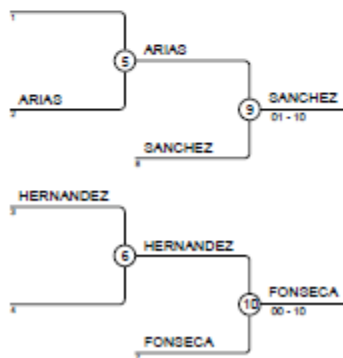

MAS SUB 15 -64KG

Competidores: 6

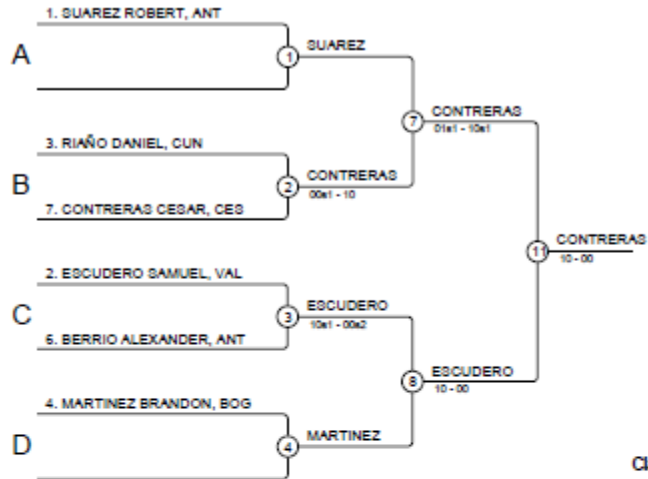

Clasificación

Pos.	Nombre
1	CONTRERAS CESAR, CES
2	ESCUDERO SAMUEL, VAL
3	RIAÑO DANIEL, CUN
3	SUAREZ ROBERT, ANT
5	MARTINEZ BRANDON, BOG
5	BERRIO ALEXANDER, ANT
7	
7	

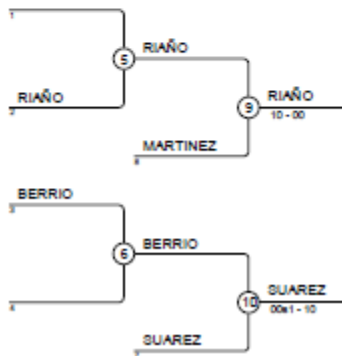

MAS SUB 15 +64KG

Competidores: 7

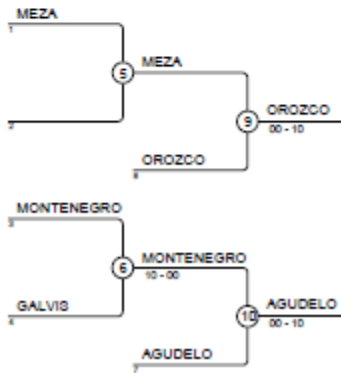
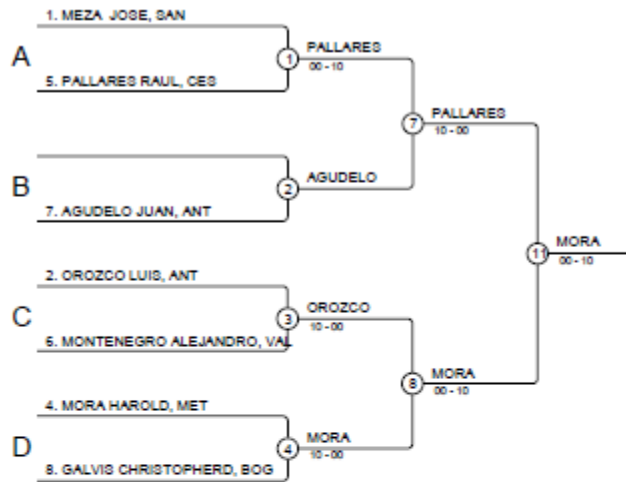

Clasificación

Pos.	Nombre
1	MORA HAROLD, MET
2	PALLARES RAUL, CES
3	OROZCO LUIS, ANT
3	AGUDELO JUAN, ANT
5	MEZA JOSE, SAN
5	MONTENEGRO ALEJANDRO, VAL
7	
7	GALVIS CHRISTOPHERD, BOG